

# Multibody Dynamics B

Spring Term 2009, Thu 15:45-17:30, Mechanical Engineering, room C, 4 ECTS credits.

## Final Project 1: Dynamic Analysis of an Ejection Seat Reverse Bungee

This thrilling ride is made up of two telescopic columns mounted on a semitrailer and a 2 seat sphere shaped vehicle connected to the upper parts of the columns by means of two bungee cords. The passenger unit is held to the base of the ride by means of a strong magnet which keeps the bungee cords stretched. After the command is given by the operator from the control panel, the magnet will release the vehicle launching it with an acceleration of  $4.8g$ . During the launch, the vehicle carries out a free looping around it's axis making the passengers scream with fear but with a great satisfaction for their new experience.

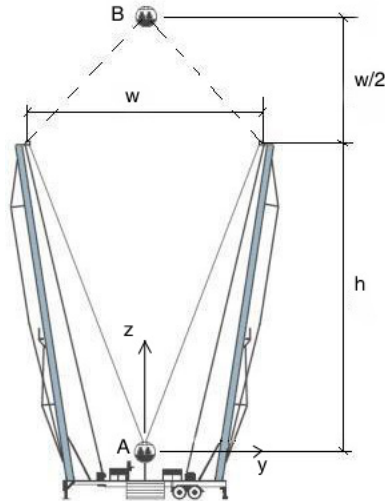

The vehicle is modelled by a rigid sphere with radius  $r = 1$  m, total mass  $m = 400$  kg, and mass moment of inertia matrix  $J = \text{diag}(170, 120, 140)$   $\text{kgm}^2$  at the center of mass (COM). The COM is located at  $\mathbf{c} = (-0.01, 0.01, -0.1)$  m relative to sphere center. The two bungee cords are connected a distance  $(0, r, 0)$  left and right of the sphere center and are modelled by linear elastic cords with a relative material damping of 10 % (in the case of a simple linear mass-spring-damper system for the cords and vehicle). The compliance  $k$  and the free length  $l_0$  of the cords are such that the vehicle has a maximal acceleration of  $4.8g$  at launch and a maximum launch height of  $h + w/2$ . Air drag is modeled by a force vector  $\mathbf{D}$  applied at the COM of the body according to

$$\mathbf{D} = -\frac{1}{2}\rho A c_d |\mathbf{v}| \mathbf{v}. \quad (1)$$

With the specific mass of the air  $\rho = 1.25$   $\text{kg/m}^3$ , the frontal area  $A = \pi r^2$ , the drag coefficient  $c_d = 0.5$ , and the velocities  $\mathbf{v}$  m/s of the COM of the vehicle. The dimensions of the supporting columns are  $h = 25$  m and  $w = 18$  m, gravity is  $g = 9.81$  N/kg.

- Determine the stiffness  $k$  and free length  $l_0$  for each bungee cord from a simple linear mass-spring model (in a first approximation we neglect the damping). Now with this stiffness determine the damping  $c$  for each bungee cord from a simple linear mass-spring-damper model.
- Determine the motion of the vehicle by numerical integration of the equations of motion over a time period of at least 30 seconds. Give a clear representation of this motion in a number of graphs of your own choose. A minimal set should include the time history of all state variables and all state derivatives and the forces in the bungee cords. Use Euler parameters for the description of the orientation of the body. Express the constrained equations of motion in the DAE form and use as state variables the position of the COM of the vehicle expressed in the global coordinate system, the four Euler parameters, the velocity of the COM expressed in the global coordinate system and the angular velocity of the vehicle expressed in the local coordinate system of the vehicle as in  $\mathbf{x} = (x, y, z, \lambda_0, \lambda_1, \lambda_2, \lambda_3, v_x, v_y, v_z, \omega'_x, \omega'_y, \omega'_z)$ . Use the coordinate projection method locally on the four Euler parameters to 'stabilize' the constraint. Since the standard ode solvers in Matlab have problems with this approach I advice to use a standard single-step numerical integrator like rk4 with fixed step-size. Make an estimate on the accuracy of your solution.
- Make a cumulative plot of the potential energy  $E_p$ , the elastic energy  $E_e$ , the translational kinetic energy  $E_{kt}$ , and the rotational kinetic energy  $E_{kr}$  for the duration of the motion. The first line is  $E_p$ , the second line is  $E_p + E_e$ , the third line is  $E_p + E_e + E_{kt}$ , and the last line is  $E_p + E_e + E_{kt} + E_{kr}$ . The zero potential energy level is assumed to be at launch. Discuss the graph.
- Clearly the apex at  $h + w/2$  is not reached. Change the properties of the ropes such that you do reach the apex (keep a relative damping of 10%). Report the values of  $k$ ,  $l_0$  and  $c$ , and show the proper motion in a number of plots. Redo the Energy plot.
- Does the vehicle make a looping? Explain and demonstrate this in a plot.
- What happens with the motion when the COM is lowered to  $\mathbf{c} = (-0.01, 0.01, -0.2)$  m?
- If one would have used so-called generalized Euler angles to describe the orientation of the vehicle and one could choose between the order of rotation  $z-x-y$  or  $z-y-x$ , which one would you prefer, and why? (Hint: draw for each option the cans-in-series).
- Prove that application of the coordinate projection method locally on the four Euler parameters is equivalent to renormalization of the Euler parameters, as in  $\lambda_i = \lambda_i / (\lambda_j \lambda_j)$  where  $i, j = 1 \dots 4$ .